

# 15

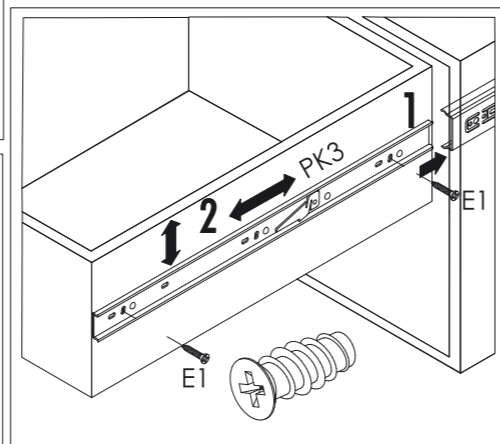

## MODELL: CN9

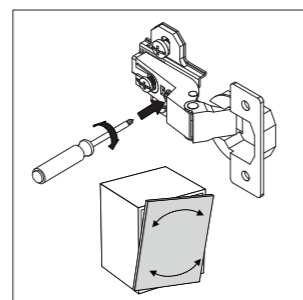
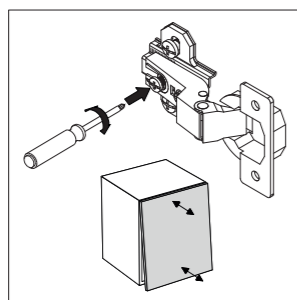
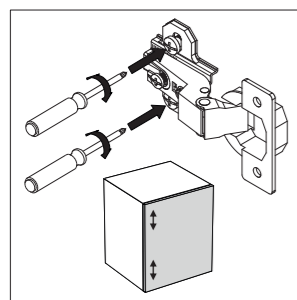
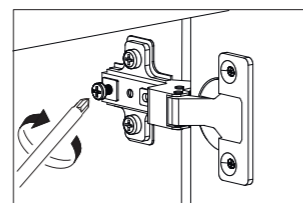
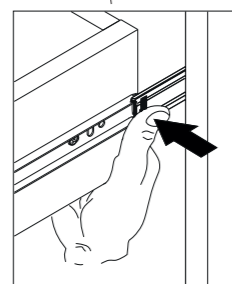
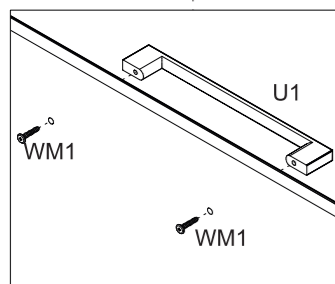
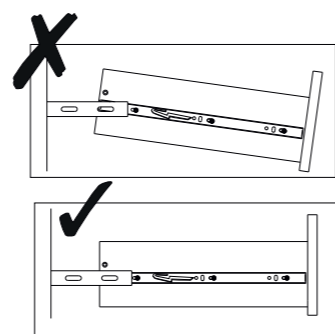
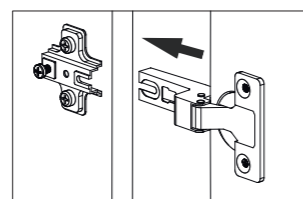
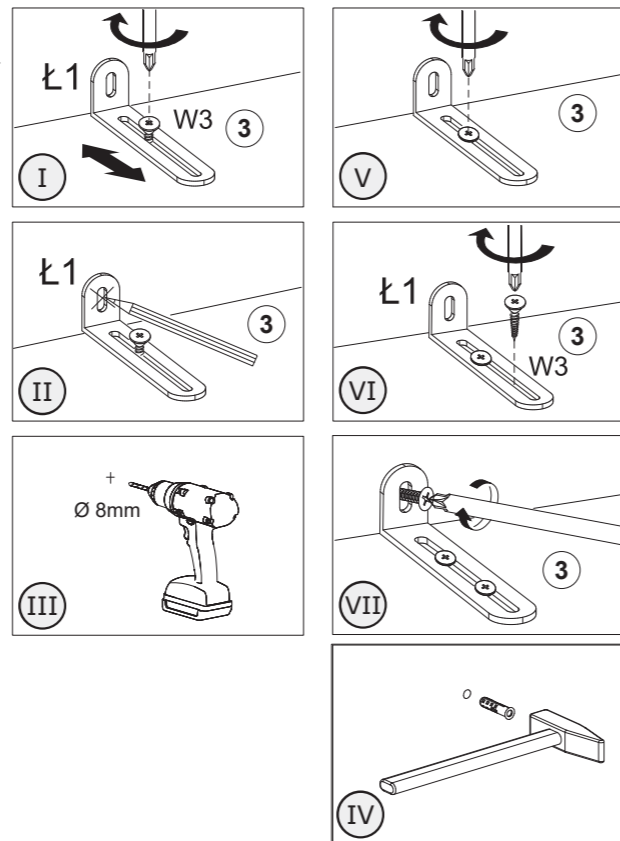
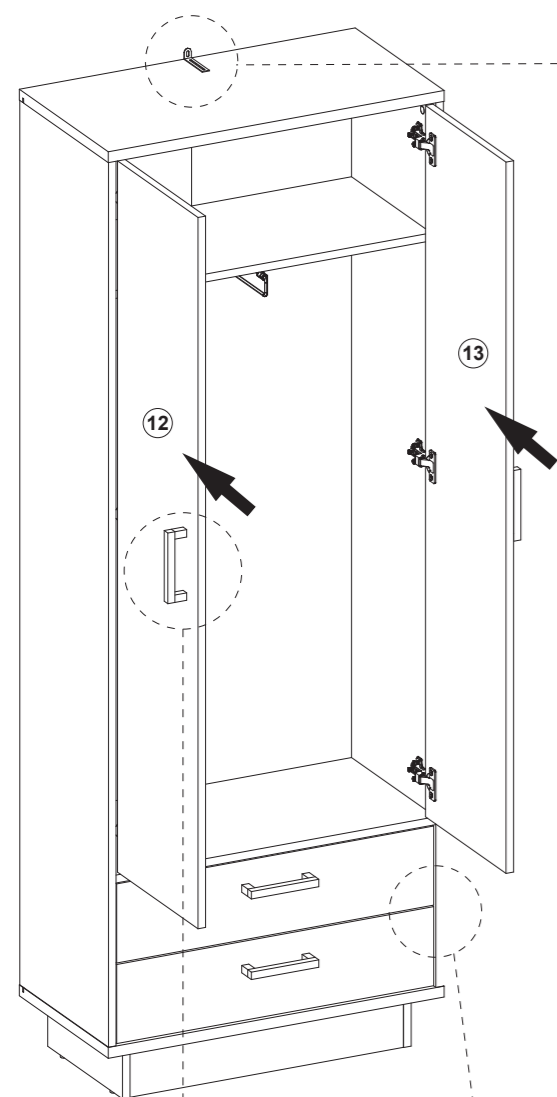
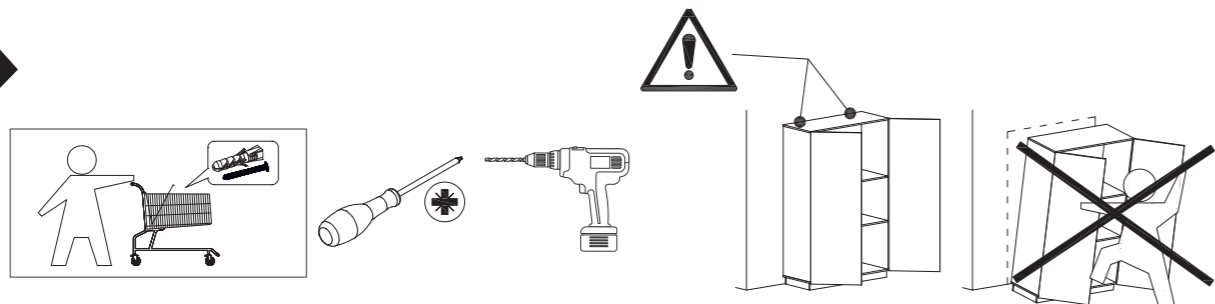
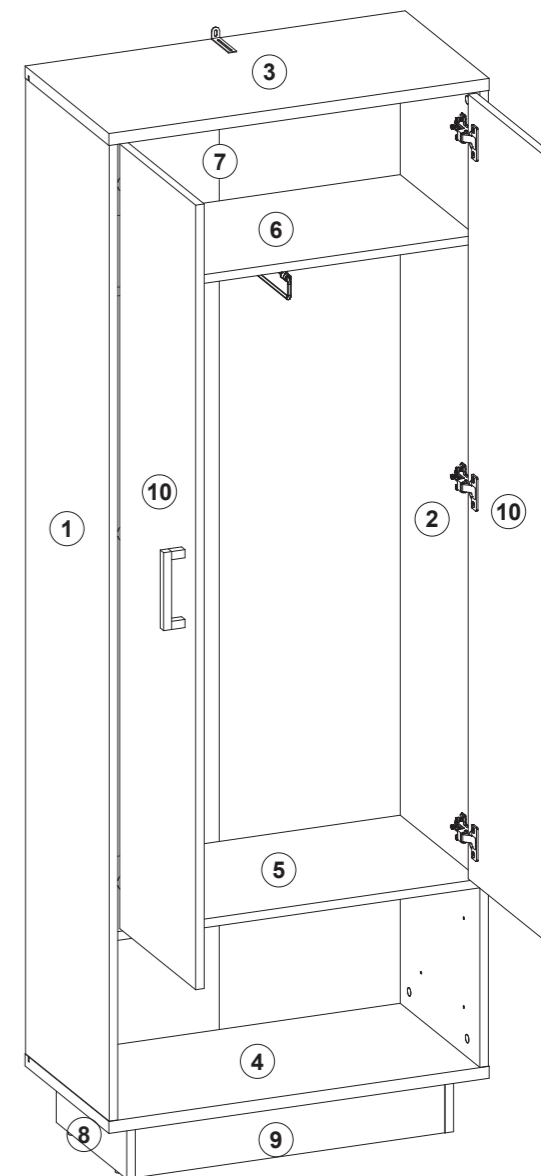
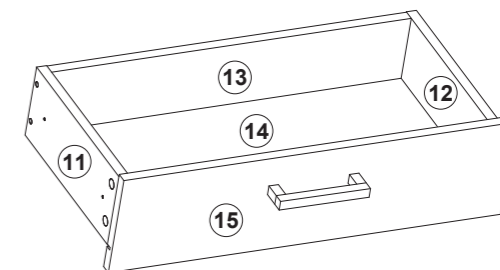
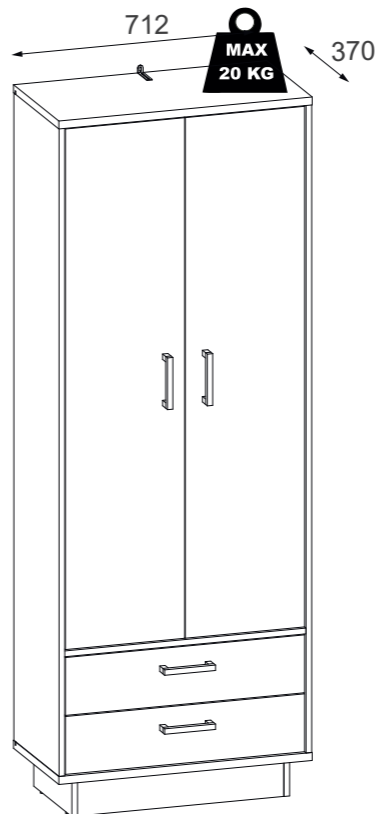
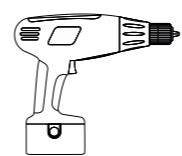
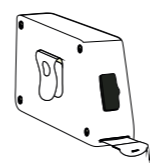
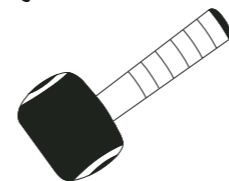
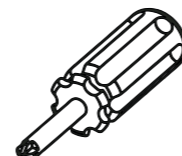
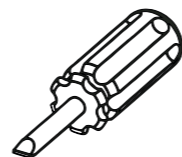

A	B (mm)		C	D
1	1790	369	16	x1 2/2
2	1790	369	16	x1 2/2
3	712	370	16	x1 1/2
4	712	370	16	x1 1/2
5	678	350	16	x1 1/2
6	678	332	16	x1 1/2
7	1806	694	2,5	x1 2/2
8	311	104	16	x2 1/2
9	580	104	16	x2 1/2
10	1439	335	16	x2 2/2
11	300	118	16	x2 1/2
12	300	118	16	x2 1/2

A	B (mm)		C	D
13	621	104	16	x2 1/2
14	636	307	2,5	x2 1/2
15	672	160	16	x2 1/2

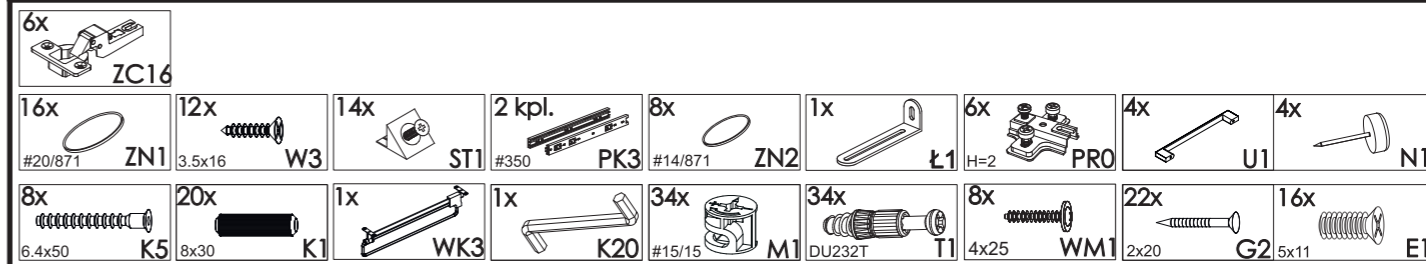

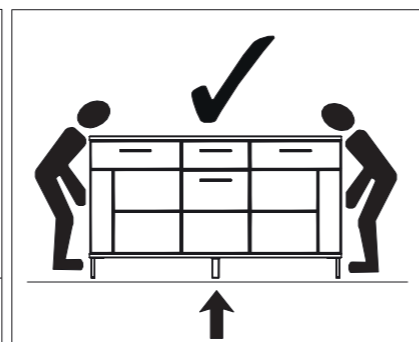
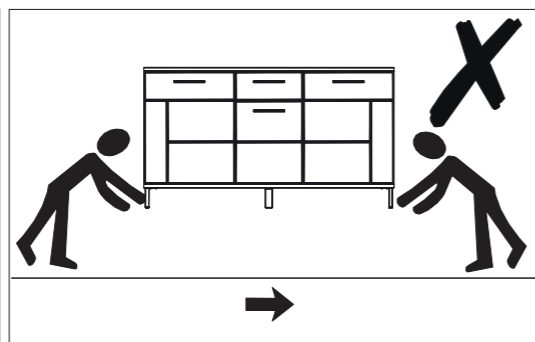
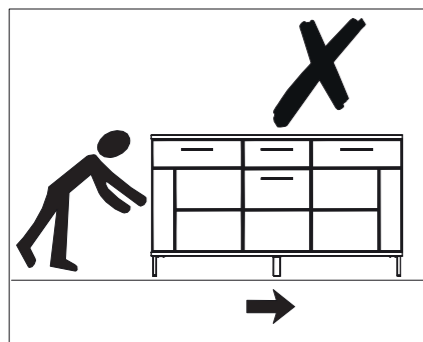
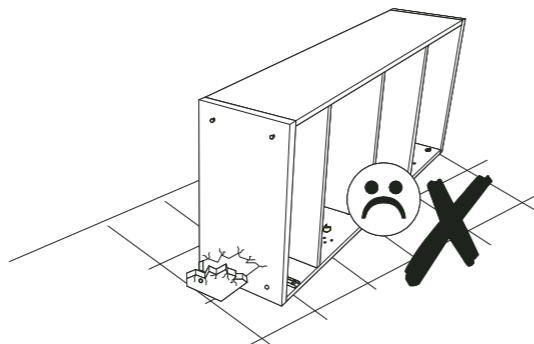
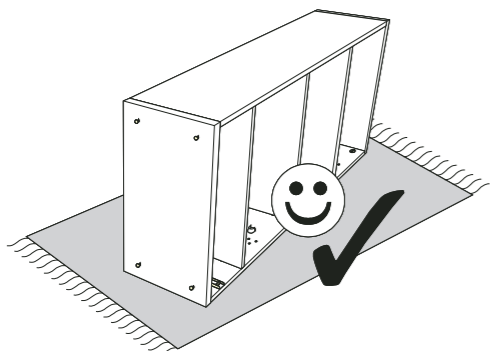
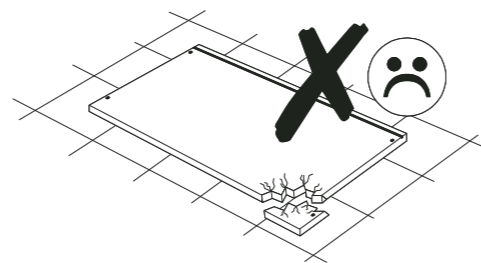
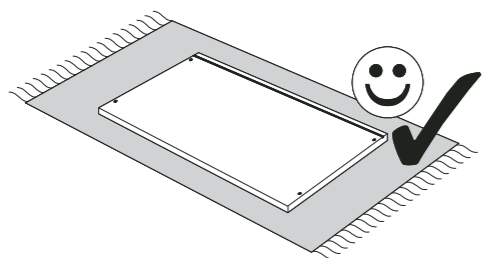
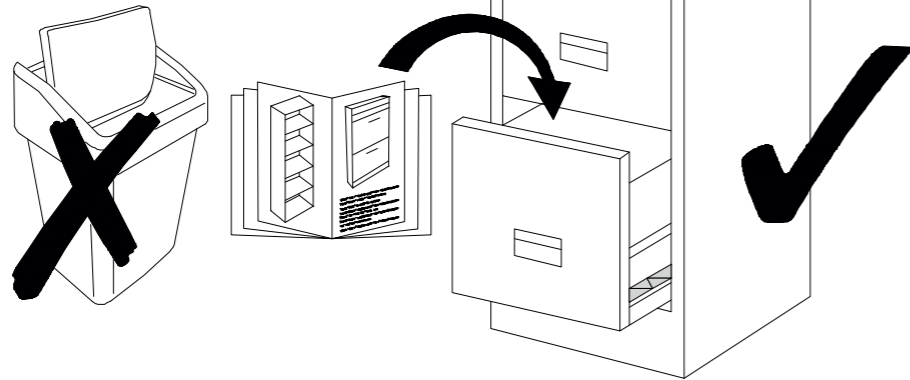

# 12

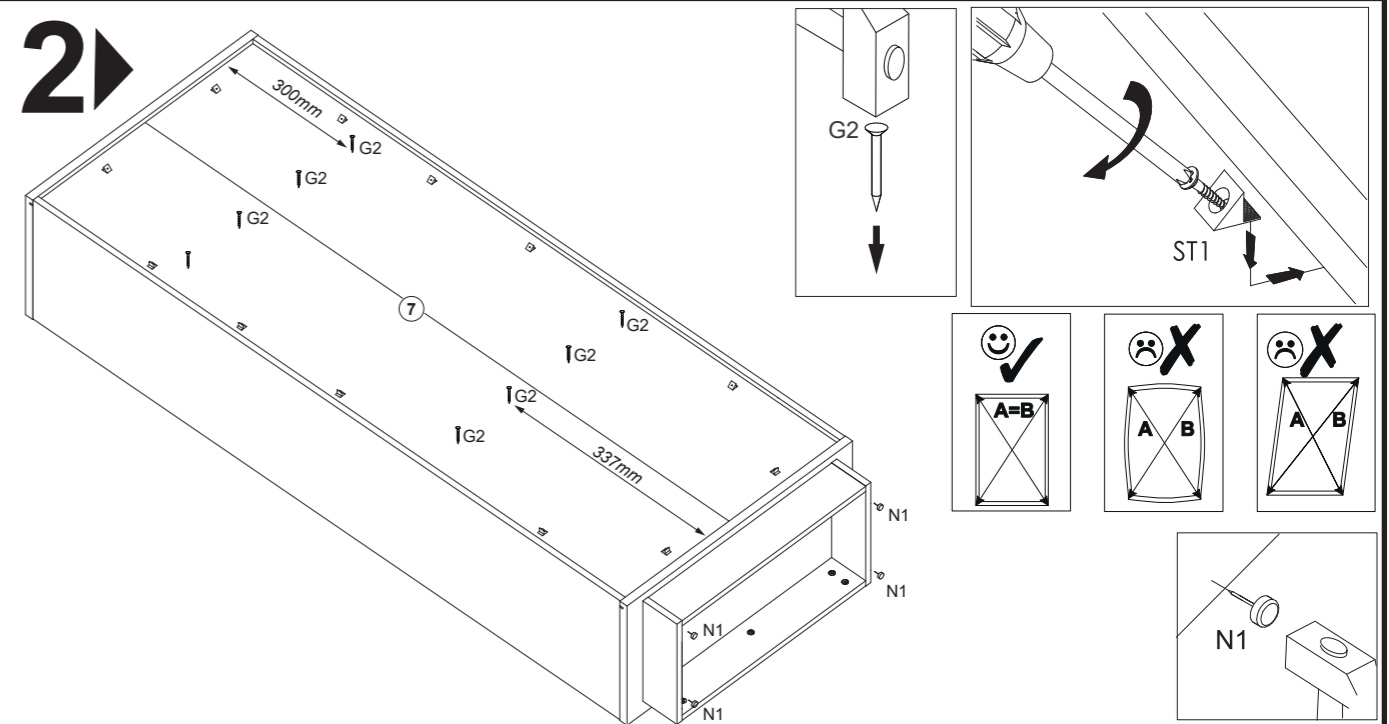

# 13

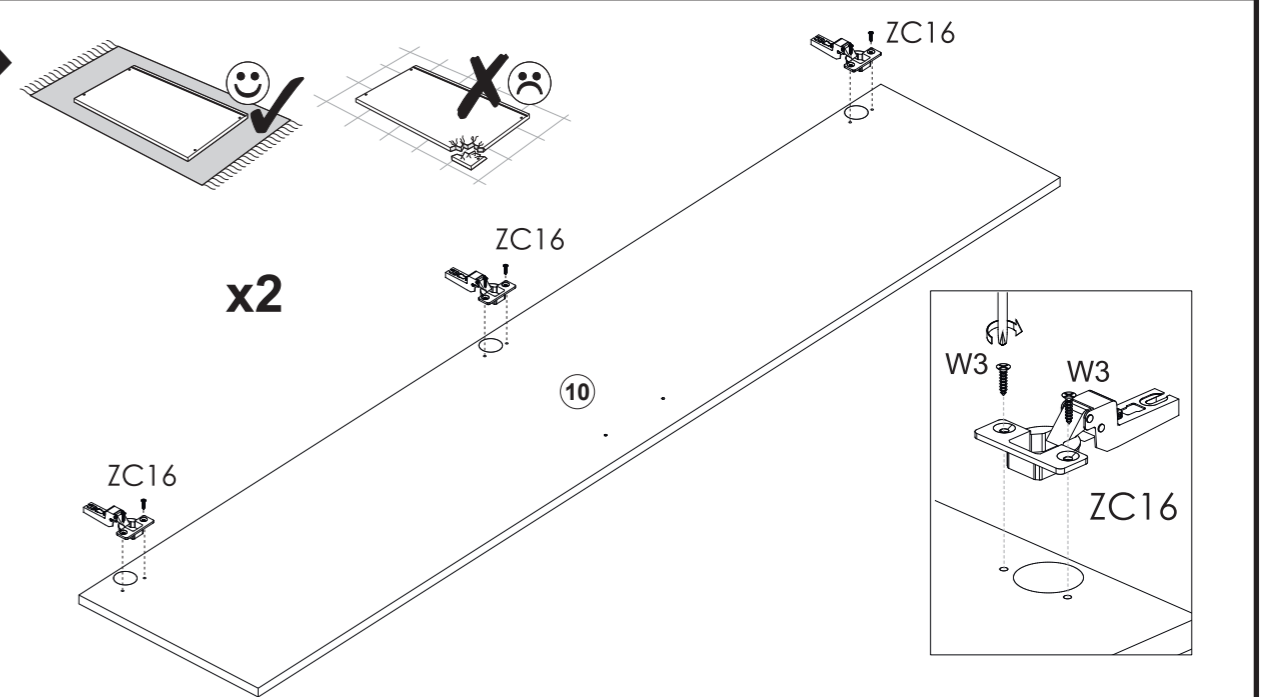

# 14

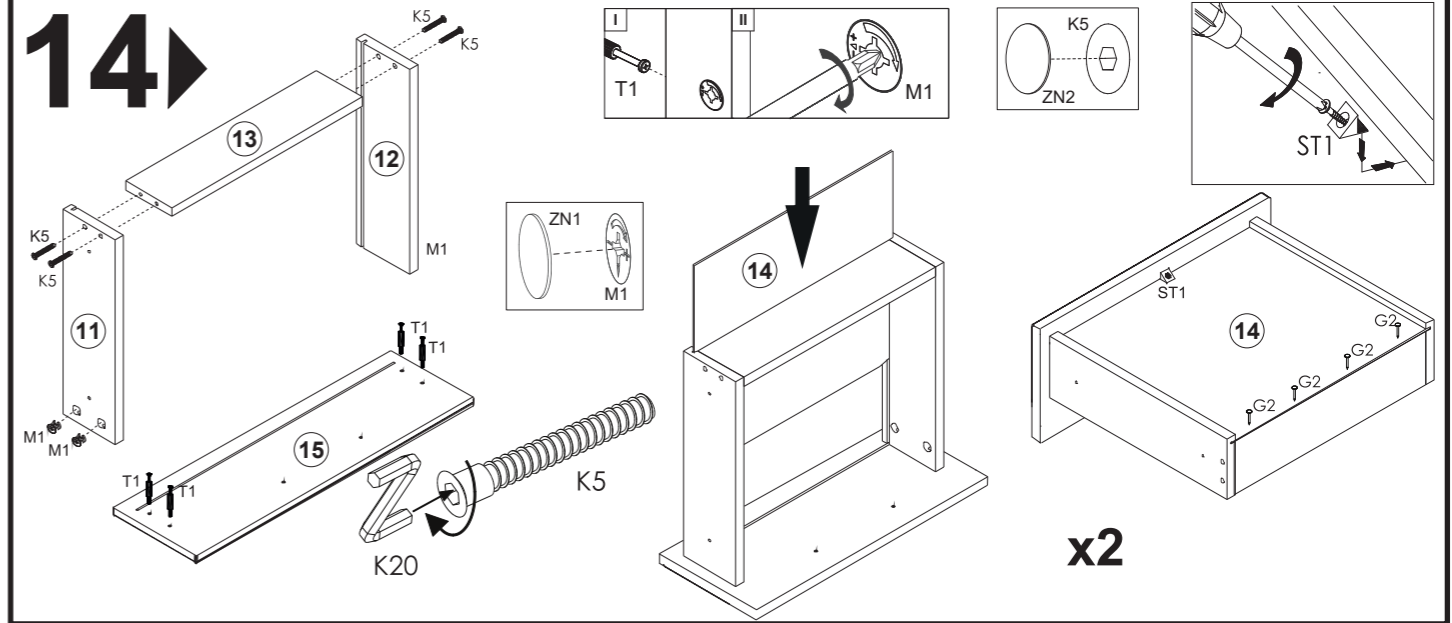

10

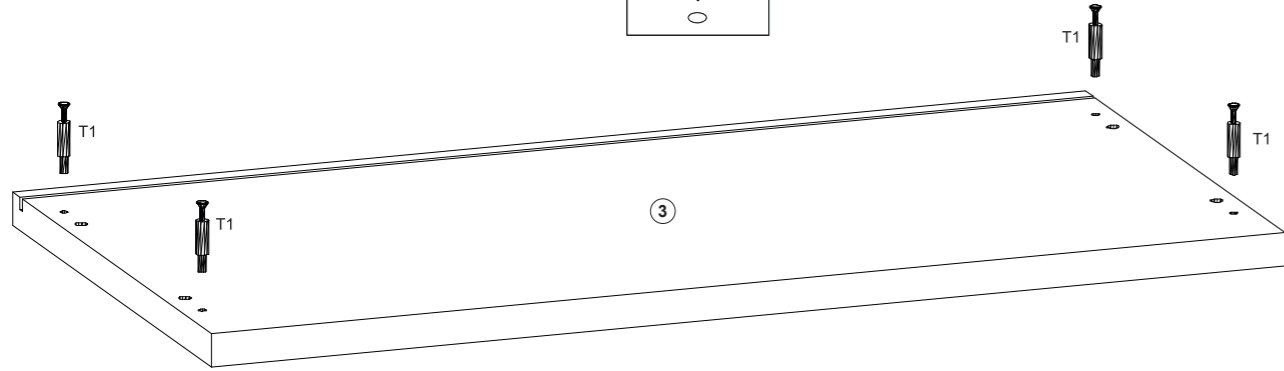
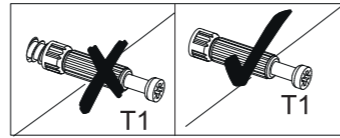
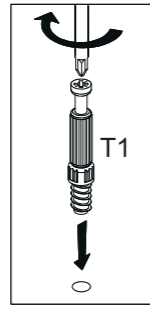

11

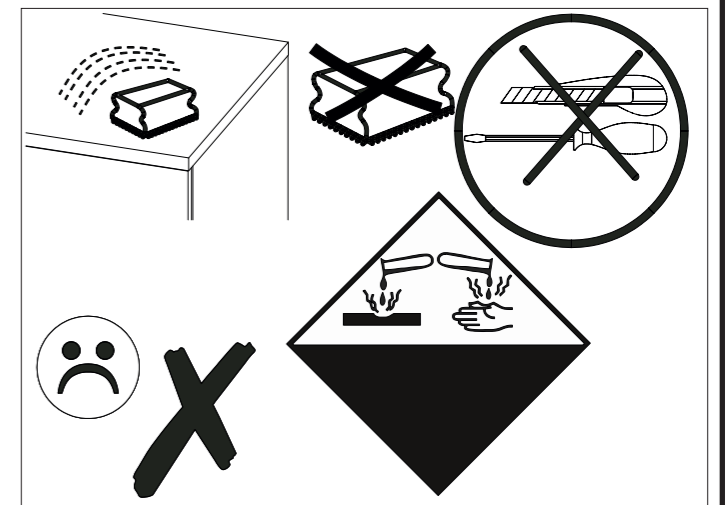
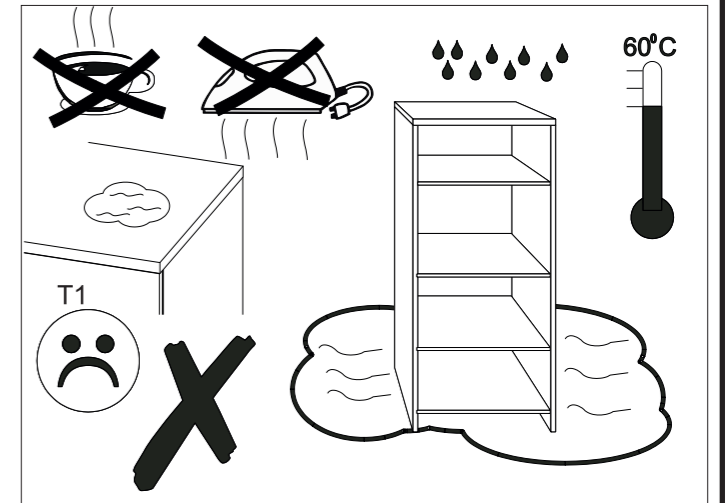
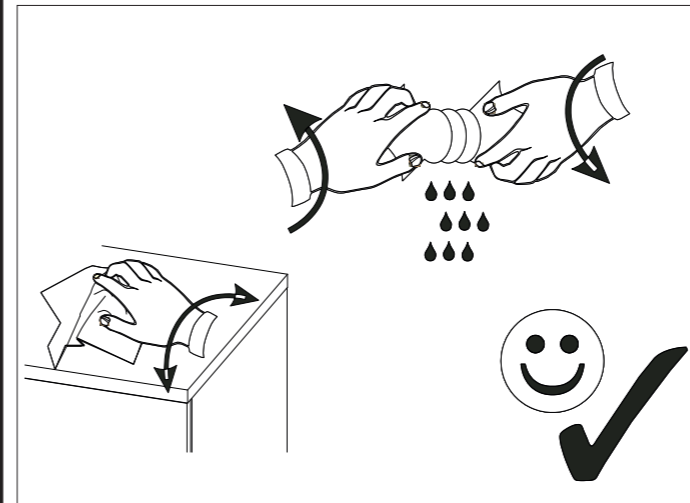
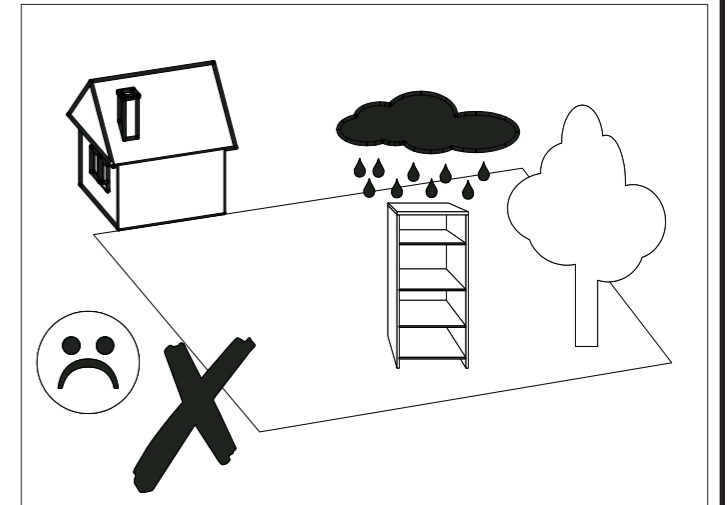
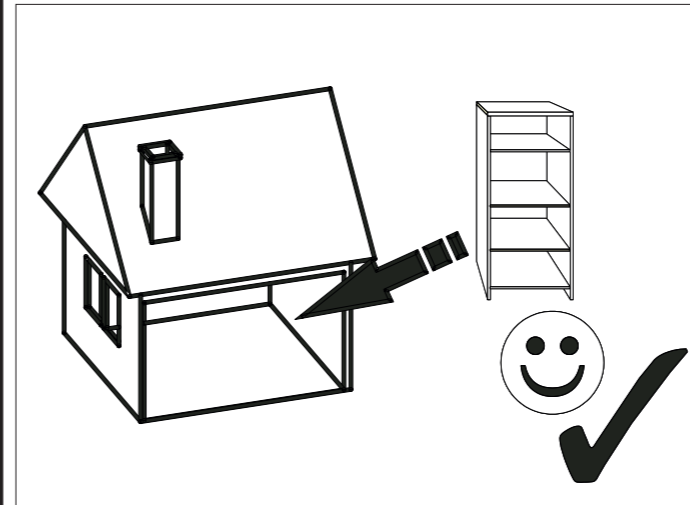
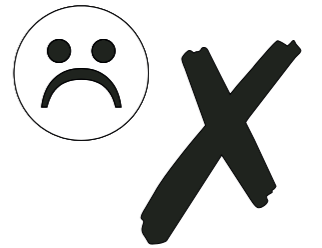
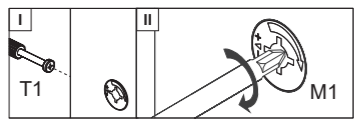
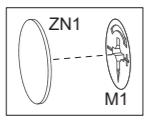
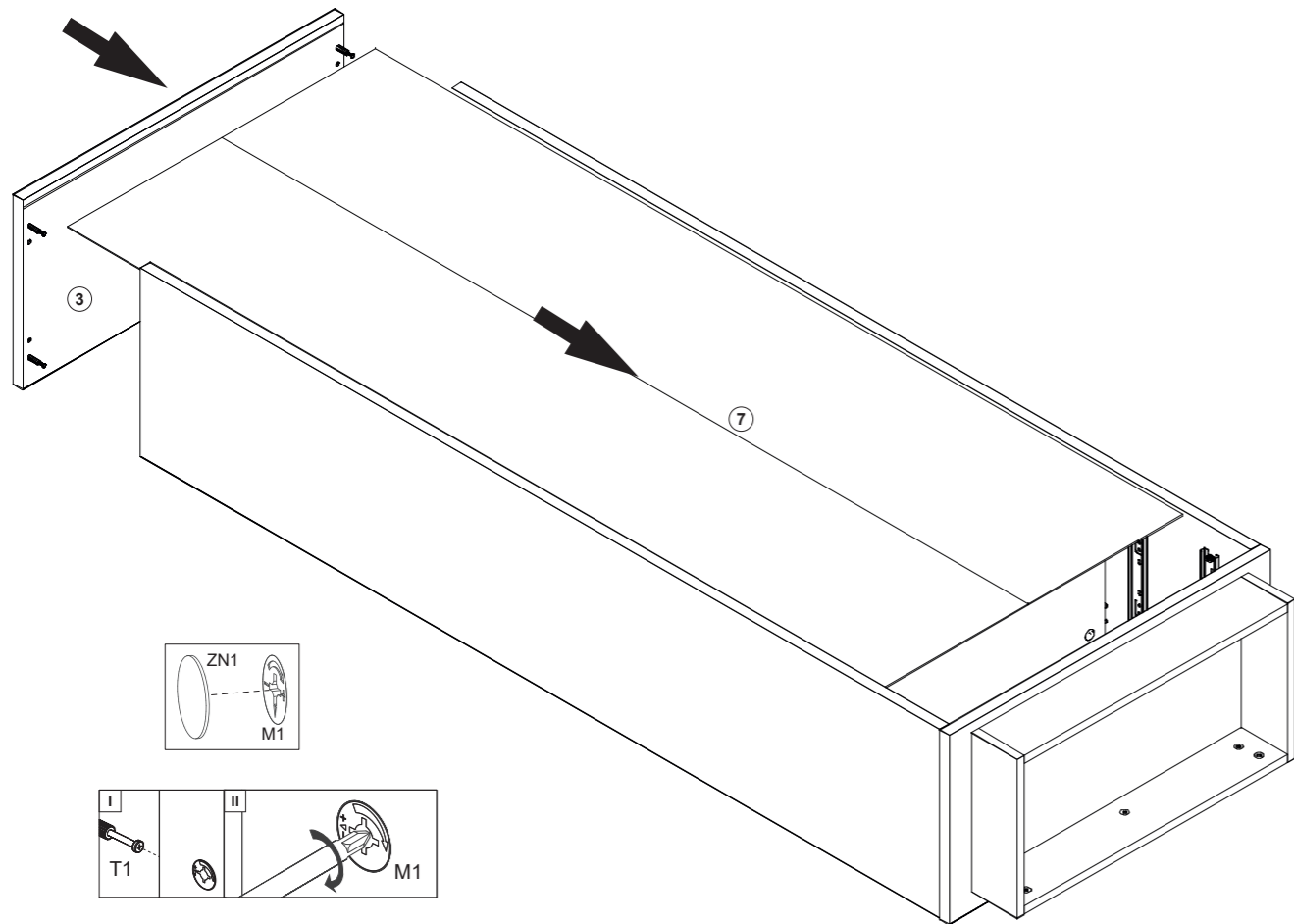

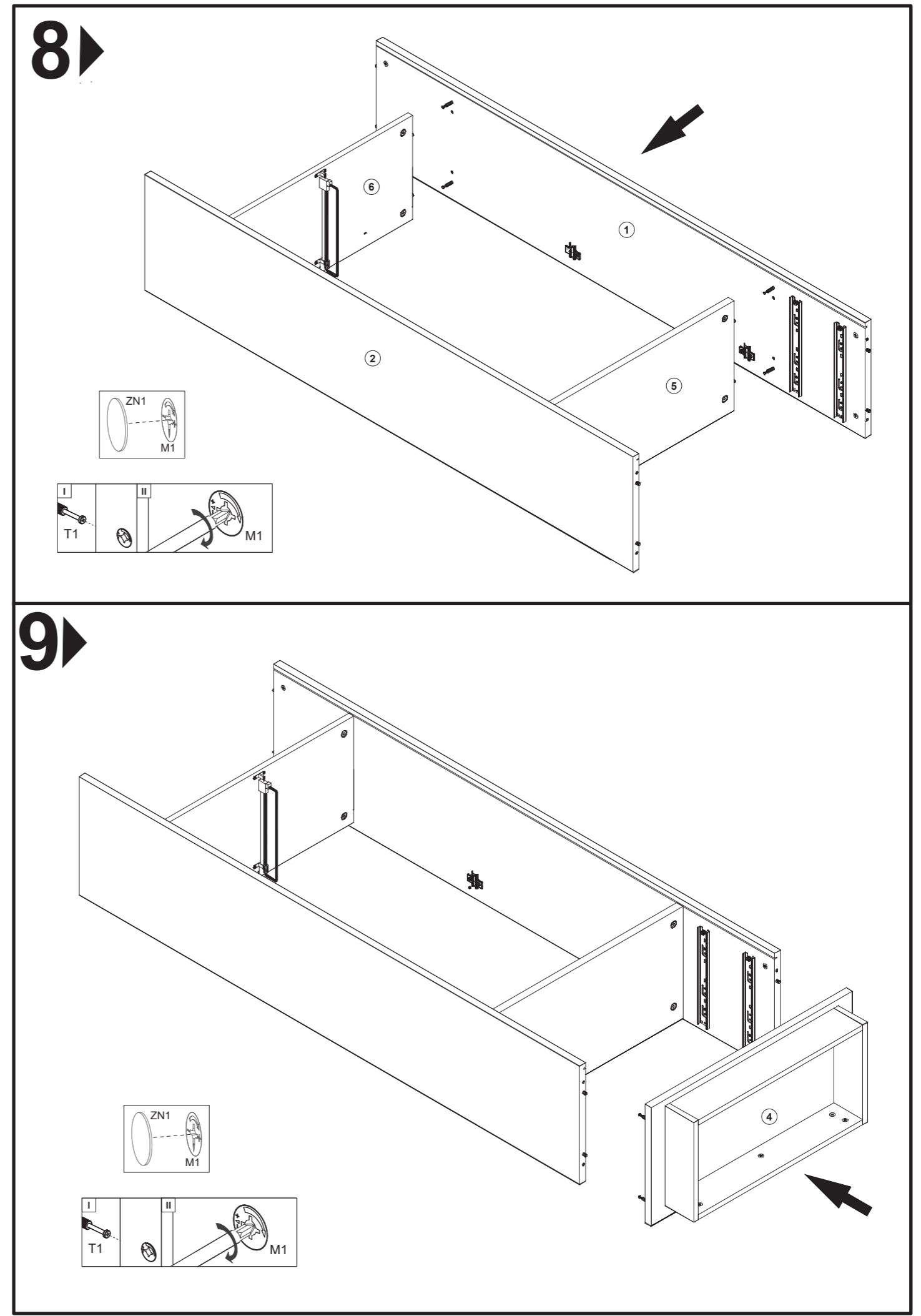
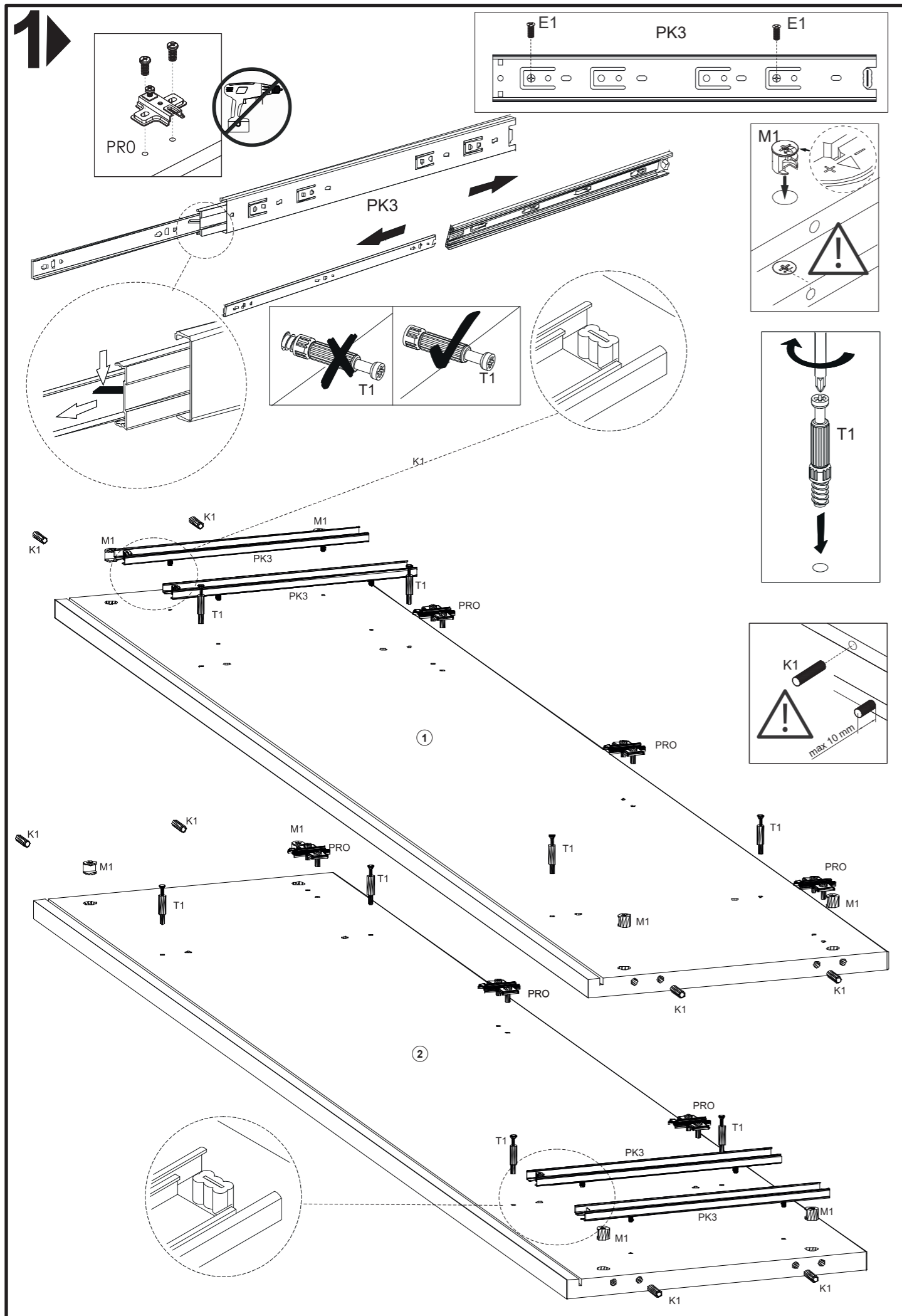

2 ▶

x2

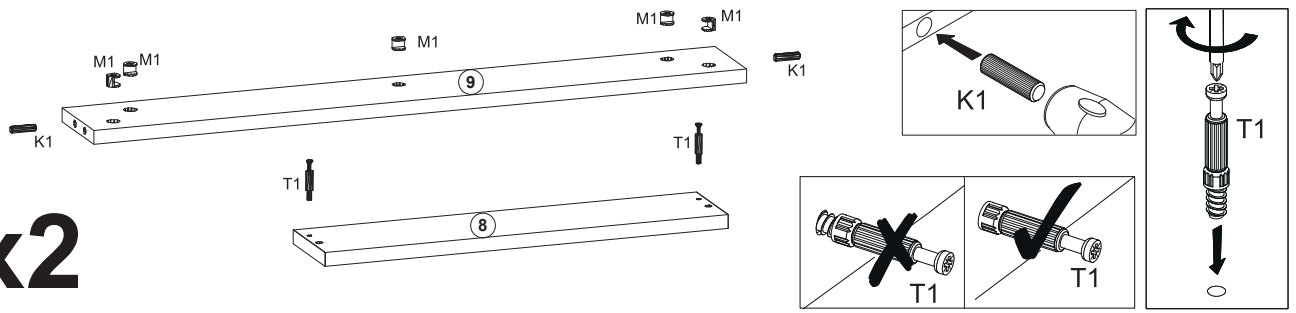

3 ▶

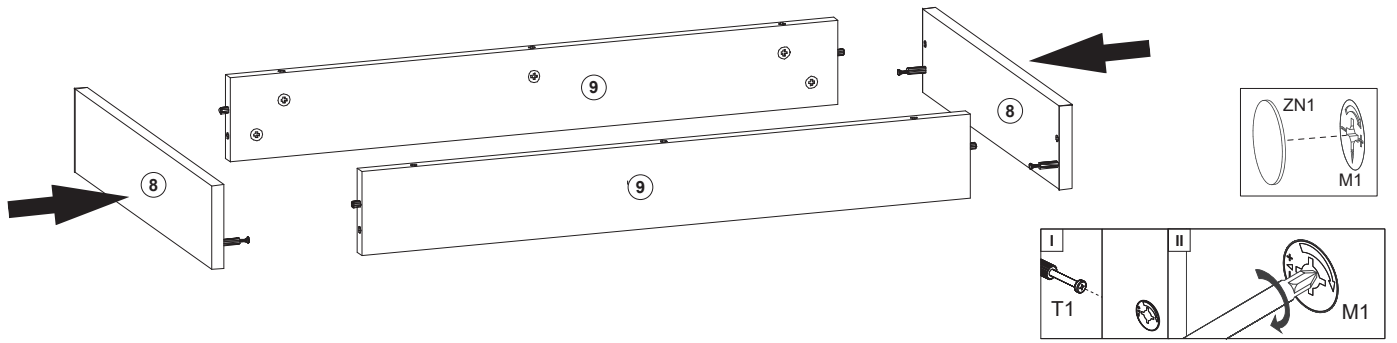

4 ▶

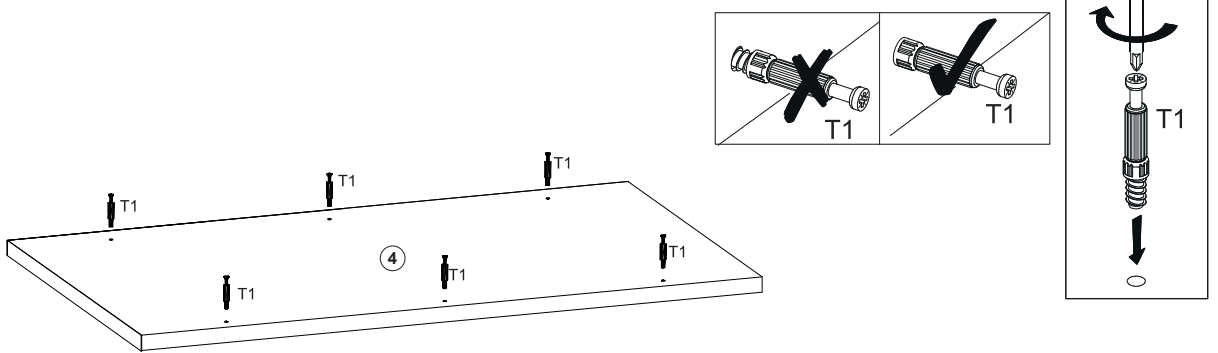

5 ▶

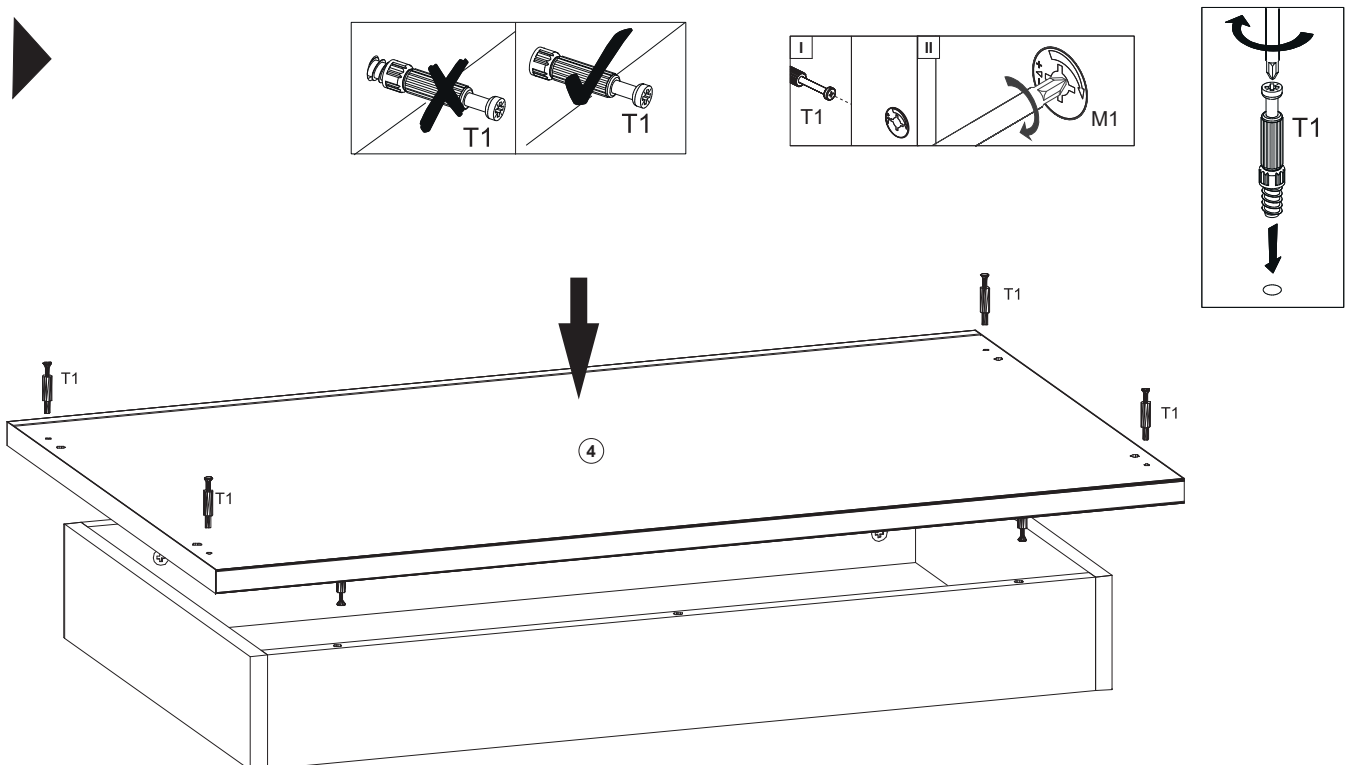

# 6

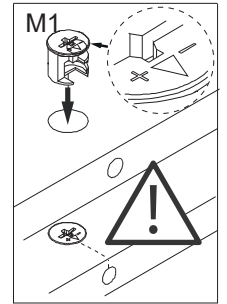
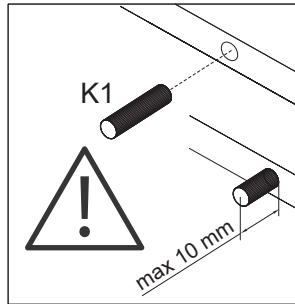
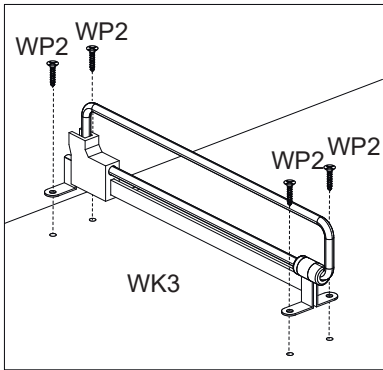
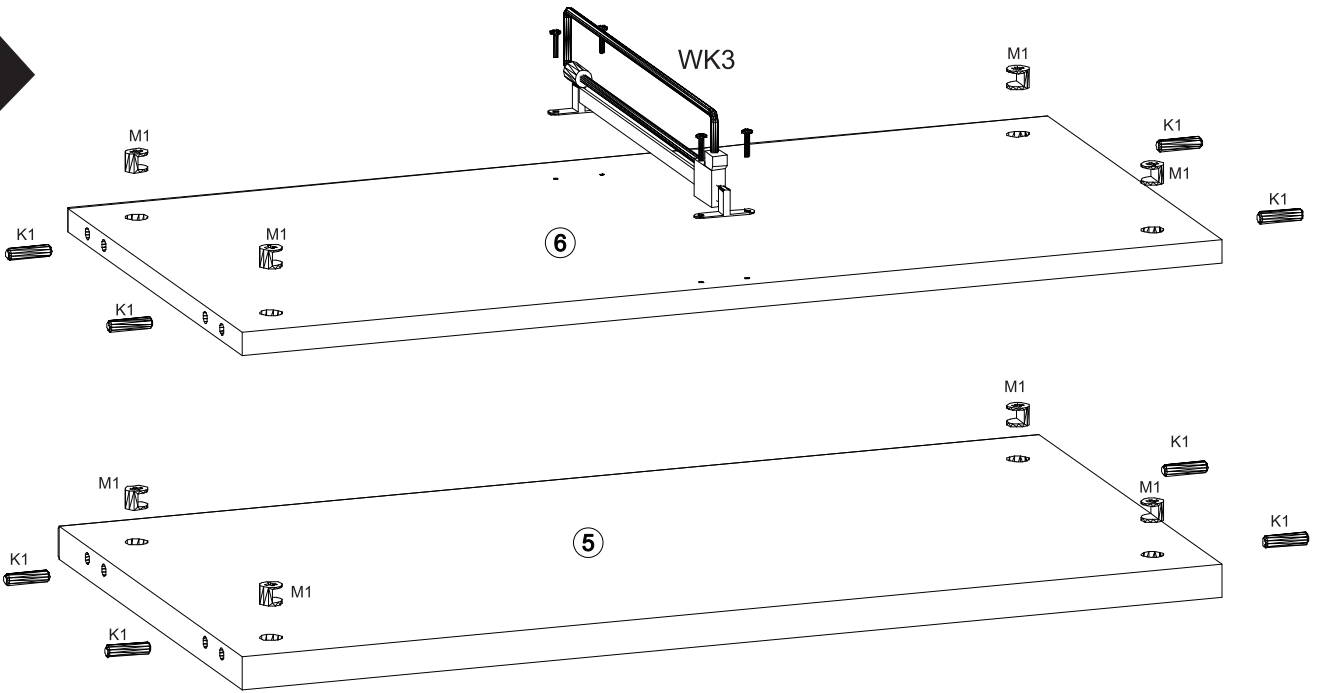

# 7

